



# Severe Service Valves

Product Data Sheet

CZ Ceramic Lined Knife Gate Valve

Knife Gate Valve

- Structural ceramics are used on the valve gate and valve-seat to resist wear, corrosion, high temperatures and thermal shock.
- Under vacuum and pressure assisted sealing.
- Materials are selected on an application basis. Options include Super Duplex Stainless Steel, Hastelloy, Stainless Steel, Cast Steel, and others, as required.
- Multiple ANSI and DIN flange standards are available. Higher classes available
- Ceramic seat materials are also selected on an application basis. Options include high alumina ceramics, silicon carbide, and others.
- Ideal for use in dry powder conveying systems, especially when under vacuum.

Used in these industries:

- Vacuum conveying systems, especially in Mining, Aluminum production, and Petrochemical industries.
- Power Production, especially in coal dust conveyance, and pneumatic ash handling.
- Suitable for Hopper/ Dry powder applications where the valve is directly loaded with material weight



## SK Valve

Buffalo, NY

Ph: (716) 795-8111 FAX: (716) 799-0969

[www.skvalveusa.com](http://www.skvalveusa.com)

CZ 8/4/09



# Severe Service Valves

## Product Specifications

## CZ Ceramic Lined Knife Gate Valve

Materials (typical)		
1	Body	SS/Carbon Steel
2	Gasket	Graphite/Viton
3	Seat	Ceramic
4	Gate	420 SS
5	Gate Plate Sealing	Ceramic
6	Packing	Graphite
7	Packing Gland	SS/Carbon Steel
8	Yoke	SS/Carbon Steel
9	Pneumatic Actuator	Optional

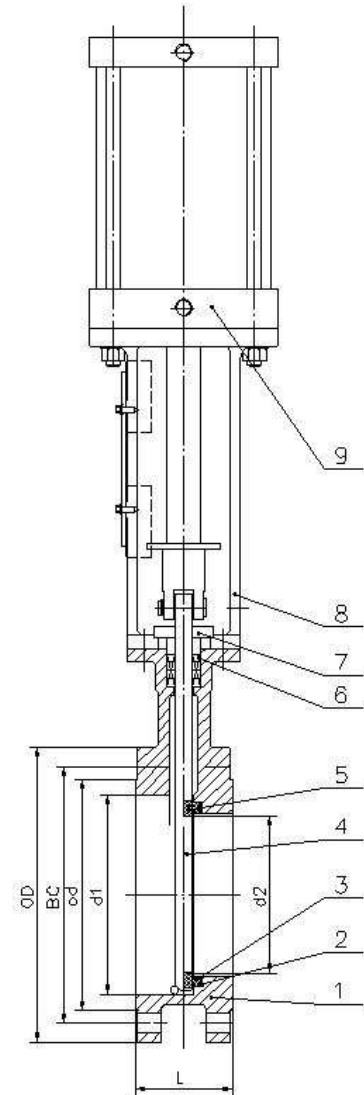

### Additional Material Choices Available

Dimensions (Inches, Class 150)										
Size		2"	3"	4"	6"	8"	10"	12"	16"	18"
Face to Face	L	1.88	2.00	2.00	2.25	2.75	2.75	3.00	3.50	3.50
Port 1	d1			3.46	5.90	7.64	9.84	12.00		
Port 2	d2			5.12	7.05	9.06	11.02	13.40		
Flange	OD	6	7.5	9	11	13.5	16	19	23.50	25.00
Bolt Circle	BC	4.75	6	7.5	9.5	11.75	14.25	17	21.25	22.75
Raised Face	od	3.62	5	6.19	8.5	10.62	12.75	15	18.50	21.00
# Holes	N	4	4	8	8	8	12	12	16	16
Drill Dia	D	5/8	5/8	5/8	3/4	3/4	7/8	7/8	1	1-1/8

\*\*This valve is designed to fit the application and dimensions will change to suit. Style CZ can be manufactured to any international standards, including MSS-SP and TAPPI for face-to-face and dimensional requirements Specifications subject to change as product enhancements take effect.

## SK Valve

Buffalo, NY

Ph: (716) 795-8111 FAX: (716) 799-0969

[www.skvalveusa.com](http://www.skvalveusa.com)

CZ 8/4/09